

Heavy Duty Class C Double Girder Series 3 Top Running Max-E-Lift Complete Cranes: Top Running Cranes for Ultimate Maximum Lift Height

Minimize wasted overhead space and maximize available lifting height with top-performing Harrington Max-E-Lift top running cranes. This double girder design and low profile trolley hoist saves much of the space "wasted" on conventional single girder designs. So for new installations, the Max-E-Lift system saves valuable overhead room and can reduce building height and construction costs. Adding a Max-E-Lift crane to an existing installation where a new, higher lifting height is required can even minimize total construction costs. Installation is easy, thanks to an assembly using bolted construction with minimal welding required and factory-installed or plug-in-type wiring connections. In operation, the compact trolley and end truck designs maximize hook coverage, as well as crane and trolley end approach. Get the standard features you want and maximum lifting height, too, with Max-E-Lift complete cranes. Capacities through 10 Ton and spans through 60 feet.

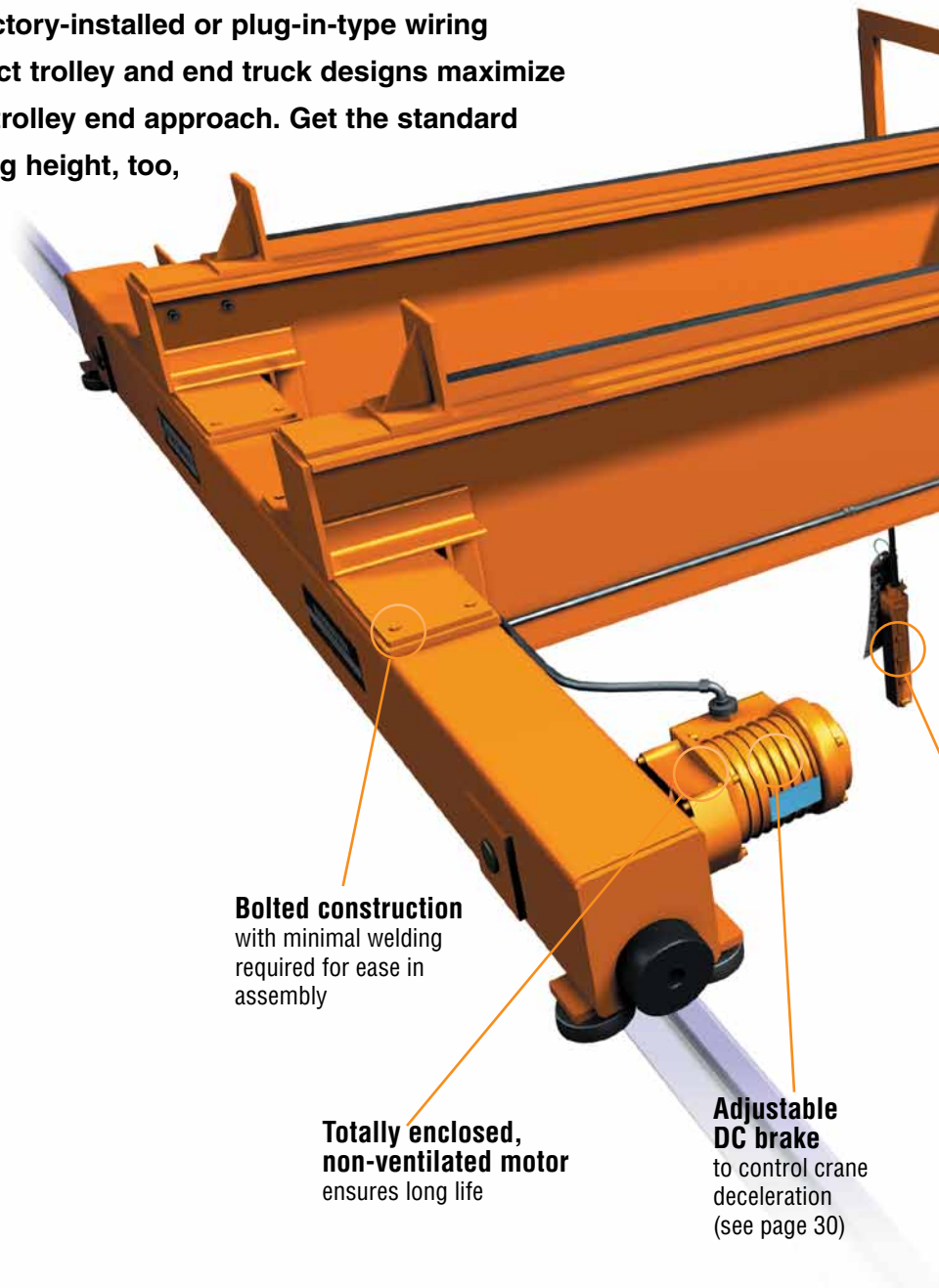

Bolted construction
with minimal welding
required for ease in
assembly

**Totally enclosed,
non-ventilated motor**
ensures long life

**Adjustable
DC brake**
to control crane
deceleration
(see page 30)

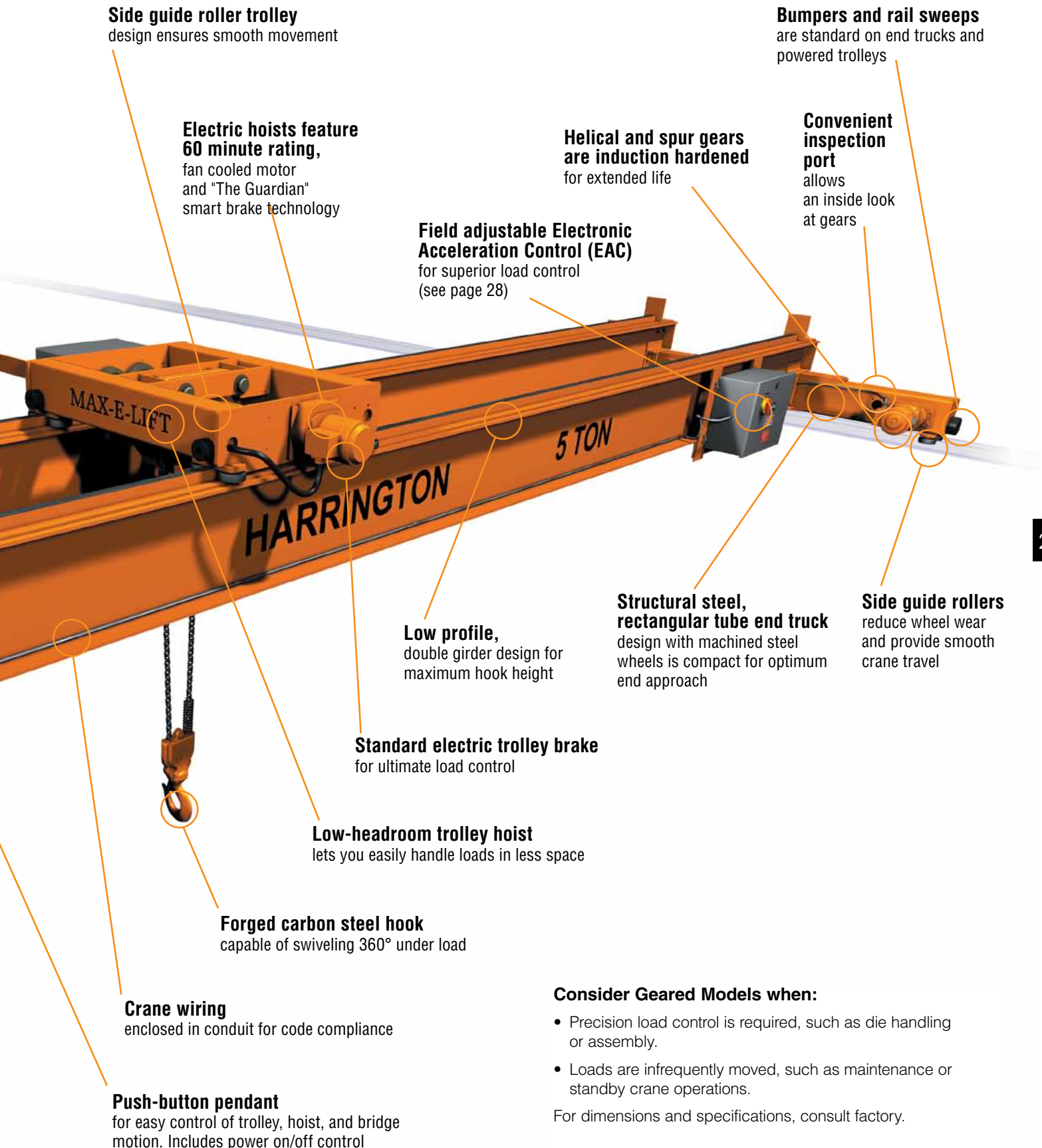

Side guide roller trolley
design ensures smooth movement

Electric hoists feature 60 minute rating,
fan cooled motor
and "The Guardian"
smart brake technology

Helical and spur gears
are induction hardened
for extended life

Bumpers and rail sweeps
are standard on end trucks and
powered trolleys

Convenient inspection port
allows
an inside look
at gears

Field adjustable Electronic Acceleration Control (EAC)
for superior load control
(see page 28)

MAX-E-LIFT

5 TON

HARRINGTON

Low profile,
double girder design for
maximum hook height

Structural steel, rectangular tube end truck
design with machined steel
wheels is compact for optimum
end approach

Side guide rollers
reduce wheel wear
and provide smooth
crane travel

Standard electric trolley brake
for ultimate load control

Low-headroom trolley hoist
lets you easily handle loads in less space

Forged carbon steel hook
capable of swiveling 360° under load

Crane wiring
enclosed in conduit for code compliance

Push-button pendant
for easy control of trolley, hoist, and bridge
motion. Includes power on/off control

Consider Geared Models when:

- Precision load control is required, such as die handling or assembly.
- Loads are infrequently moved, such as maintenance or standby crane operations.

For dimensions and specifications, consult factory.

Heavy Duty Class C Double Girder Series 3 Underhung Max-E-Lift Complete Cranes: Underhung Cranes for Maximum Lift Height

Harrington Max-E-Lift underhung double girder cranes pack superior system performance into a space-saving, underhung profile. As a result, they save much of the space "wasted" by conventional single girder designs. For new installations, the Max-E-Lift system saves valuable overhead room and can reduce building height and construction costs. When replacing a conventional single girder underhung crane with a Max-E-Lift system, you can reduce wasted space and total construction costs. Installation is easy, thanks to an assembly using all bolted construction and factory-installed or plug-in-type wiring connections. In operation, the compact trolley and end truck designs maximize hook coverage, as well as crane and trolley end approach.

Get the standard features you want and maximum lifting height, too, with Max-E-Lift complete crane systems. Capacities through 5 Ton and spans through 50 feet.

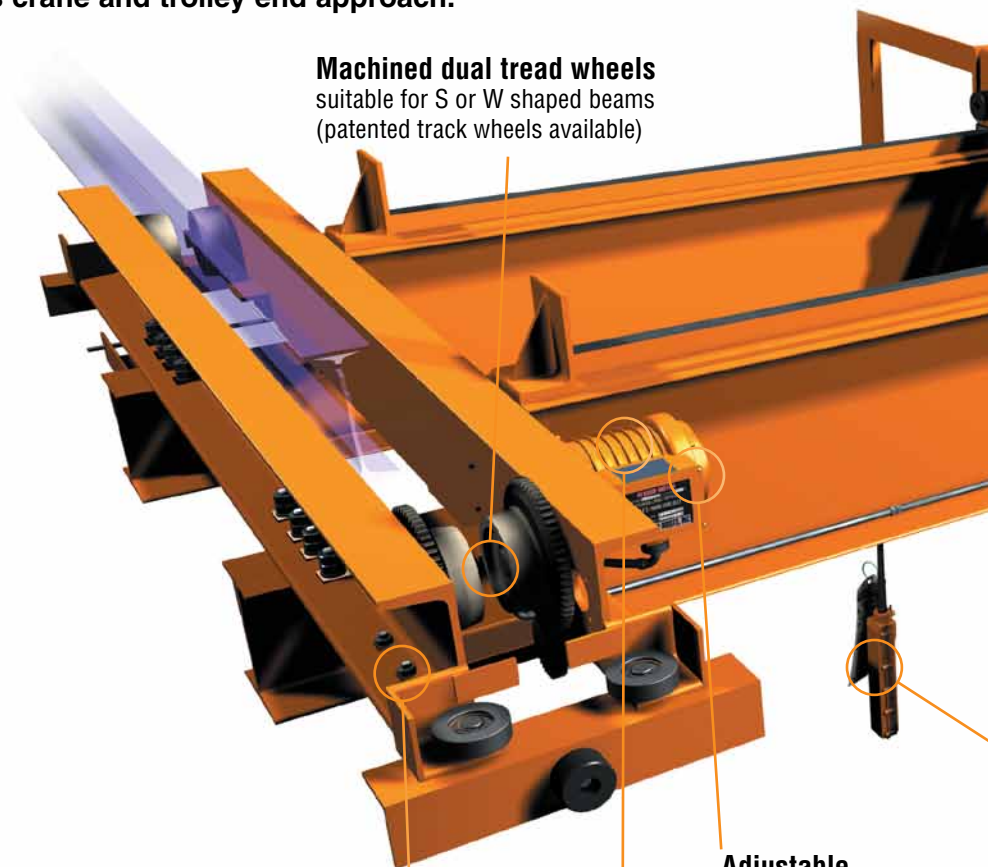

Machined dual tread wheels
suitable for S or W shaped beams
(patented track wheels available)

Adjustable DC brake
to control crane deceleration
(see page 30)

All bolted construction
for ease in assembly

Totally enclosed, non-ventilated motor
ensures long life

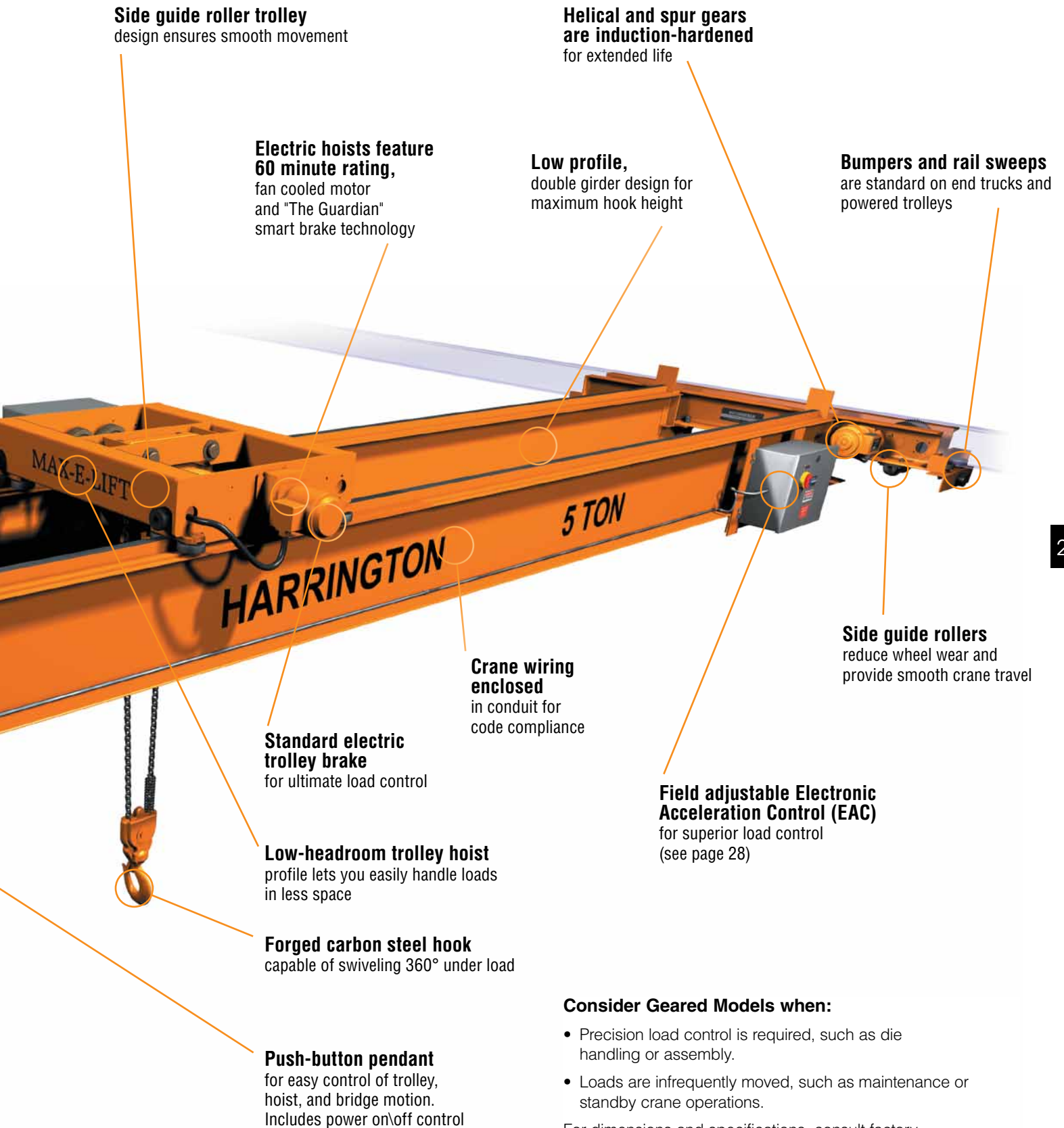

Side guide roller trolley
design ensures smooth movement

Helical and spur gears
are induction-hardened
for extended life

Electric hoists feature 60 minute rating,
fan cooled motor
and "The Guardian"
smart brake technology

Low profile,
double girder design for
maximum hook height

Bumpers and rail sweeps
are standard on end trucks and
powered trolleys

MAX-E-LIFT

HARRINGTON

5 TON

Standard electric trolley brake
for ultimate load control

Crane wiring enclosed
in conduit for
code compliance

Side guide rollers
reduce wheel wear and
provide smooth crane travel

Low-headroom trolley hoist
profile lets you easily handle loads
in less space

Field adjustable Electronic Acceleration Control (EAC)
for superior load control
(see page 28)

Forged carbon steel hook
capable of swiveling 360° under load

Consider Geared Models when:

- Precision load control is required, such as die handling or assembly.
- Loads are infrequently moved, such as maintenance or standby crane operations.

For dimensions and specifications, consult factory.