



INTORQ

setting the standard

BFK 470 spring-applied brake

Degree of protection IP66

40 – 250 Nm

www.intorq.de

We set the standards

The INTORQ brand stands for reliable brake solutions of the highest standard. Whether in cranes, wind turbines or lift systems – INTORQ products are used in the most diverse of applications. Rely on us to create the right solution for your drive – individually and reliably.

With its broad scope of different versions, the modular range of INTORQ products is used in many motors and geared motors and has set standards worldwide. With the establishment of facilities in Shanghai and Atlanta, we have also consistently expanded our international presence. So wherever you are in the world, our network of sales and service staff is always close at hand to support you.



INTORQ at a glance

- Electromagnetic brakes and clutches
- Configurable standard solutions and custom-made solutions
- Development and production centred in Aerzen
- Fast delivery times worldwide thanks to production sites in Shanghai and Atlanta
- 45 million euros a year sales volume
- 800,000 units a year
- 10,000 square metres production area
- 220 employees
- Market leader with 63 sales partners in 49 countries



BFK470 – for increased requirements

The INTORQ range of spring-applied brakes is being expanded with the addition of the BFK470 series of sealed designs. This brake has been specifically developed for application areas that place increased requirements on the degree of protection. It is a self-contained system available in three sizes, and with braking torques of 40 - 250 Nm it is ideal for use in wind power plants, cranes and textile machines.

Features

- Degree of protection corresponding to IP66, also available with hand release and inductive proximity switch
- Option of mounting a rotary transducer
- Wear can be measured when mounted
- Can be used up to -40°C (CCV Cold Climate Version)

Fields of application

- Brake motors
- Wind turbines
- Car wash systems
- Cranes
- Lift applications
- Textile machines



Wind turbines



Car wash systems



Cranes

INTORQ BFK470-□□ product key

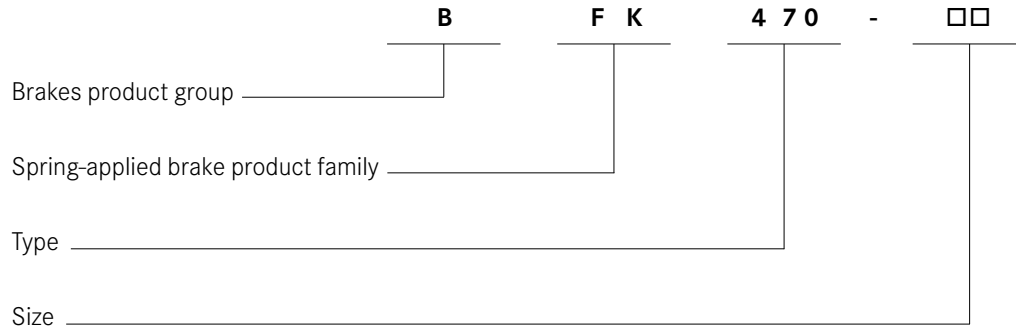

Sizes

14, 16, 18

Stator design

Brake designs with and without flange
Degree of protection up to IP66 (optional)

Not coded:
Supply voltage, hub bore,
options

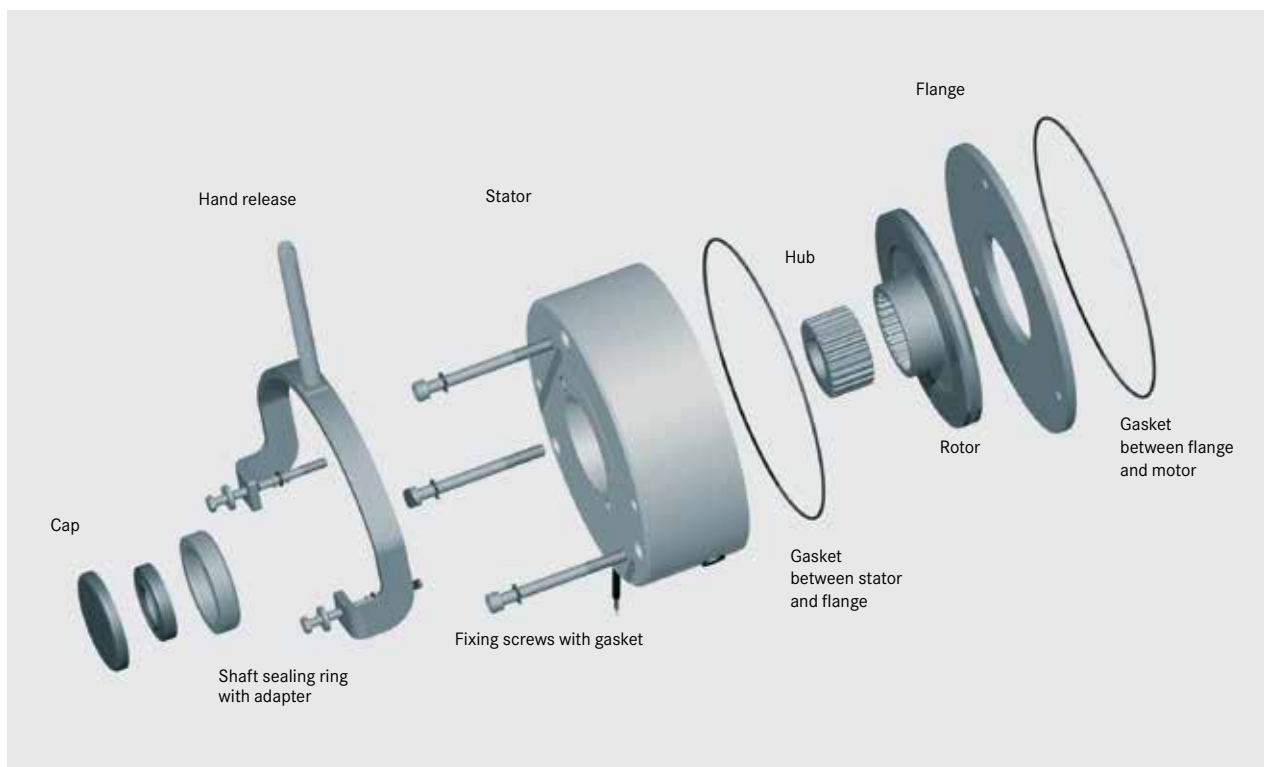

Product information

A powerful and complete range

- 3 sizes
- Standard voltages [V DC] 24, 103, 180, 205
- Graduated torque range from 40 - 250 Nm
- Degree of protection up to IP66

Torque transmission

- Designed for dry running

Quick and easy mounting

- Preset air gap
- Special machining of the friction surfaces ensures that the characteristic torques are achieved after very few switching operations
- No locating bearing is required on the brake

Durable

- The insulation system to temperature class F (155°C) ensures that the winding has a long service life
- The brakes are designed for 100% duty time (current applied to the brake)

Low maintenance

- Long rotor/hub connection with low rate of wear and a tried-and-tested involute gear

- Asbestos-free and solvent-free friction lining with low rate of wear

Options

- Hand release according to degree of protection IP66 for all sizes, both directions can be used for release
- Noise-reduced rotor
- Contactless proximity switch according to degree of protection IP66 carries out function monitoring
- Non-standard voltages and bores on request
- Pulse width modulation (PWM)
Partial discharge free brake has been developed for operation with the pulse width modulated DC bus voltage of a frequency inverter
Rated coil voltage $U_N=103V$ DC

Temperature resistant up to -40 °C

- Optional CCV (Cold Climate Version) design
- Use of temperature-resistant fixing screws is essential
- Also available with noise-reduced rotor
- Contactless proximity switch ready for operation (information evaluation) up to -25°C, approved for use up to -40°C (without component damage)

List of abbreviations

P_N	[W]	Rated coil power at rated voltage and 20°C	S_{LN}	[mm]	Rated air gap
U_N	[V DC]	Rated coil voltage	S_{Lmax}	[mm]	Maximum air gap
M_K	[Nm]	Rated torque of the brake, at a relative speed of 100 r/min	t₁	[s]	Engagement time, the total of the reaction delay and torque rise time $t_1 = t_{11} + t_{12}$
Δn₀	[r/min]	Initial relative speed of the brake	t₂	[s]	Disengagement time, time from switching the stator until the torque has reduced to 0.1 M _K
Q	[J]	Heat/energy	t₃	[s]	Slipping time to standstill (after t ₁₁)
Q_E	[J]	Maximum permissible friction work per switching cycle, thermal rating of the brake	t₁₁	[s]	Delay time when connecting, time from disconnecting the voltage until the torque begins to rise
Q_{Smax}	[J]	maximum permissible friction work during cyclic switching, depending on the operating frequency	t₁₂	[s]	Rise time of braking torque, time from beginning of rise of torque until braking torque is reached
S_h	[1/h]	Operating frequency, the number of repeated operations per unit time			
S_{hmax}	[1/h]	Maximum permissible operating frequency, depending on the friction work per operation			

Technical data

BFK470 spring-applied brake

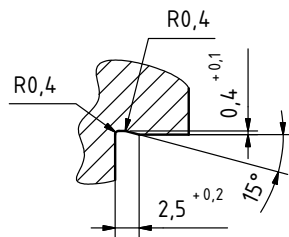
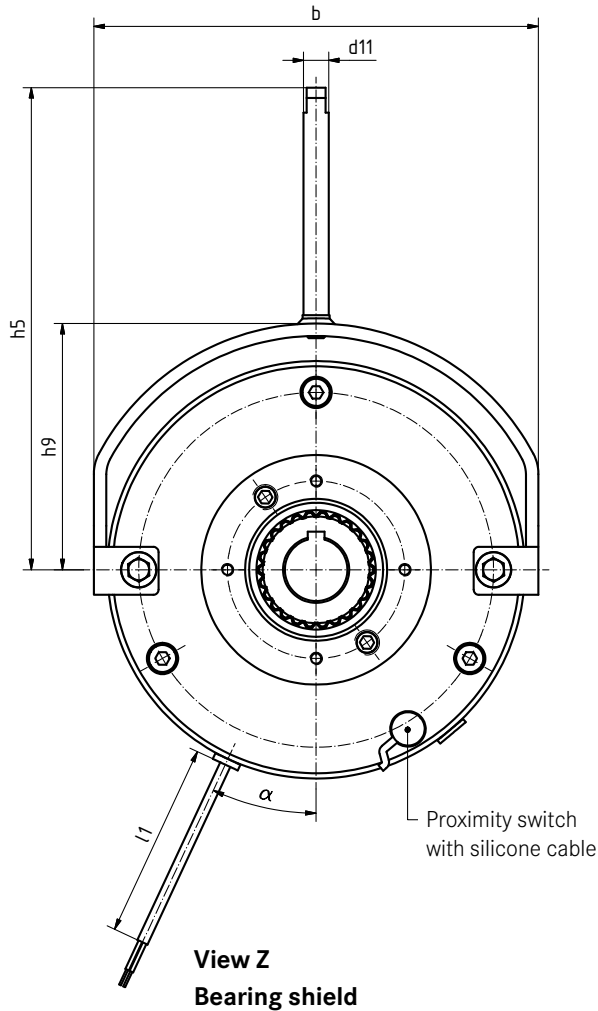

Brake with flange

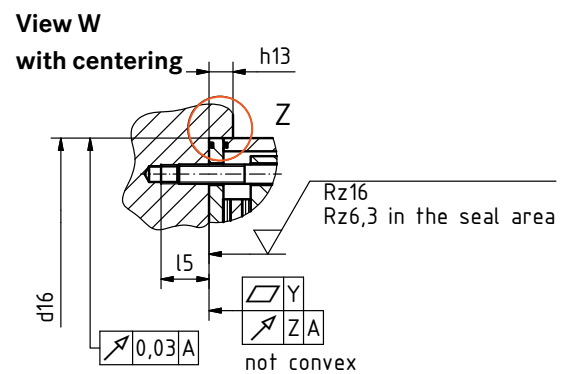
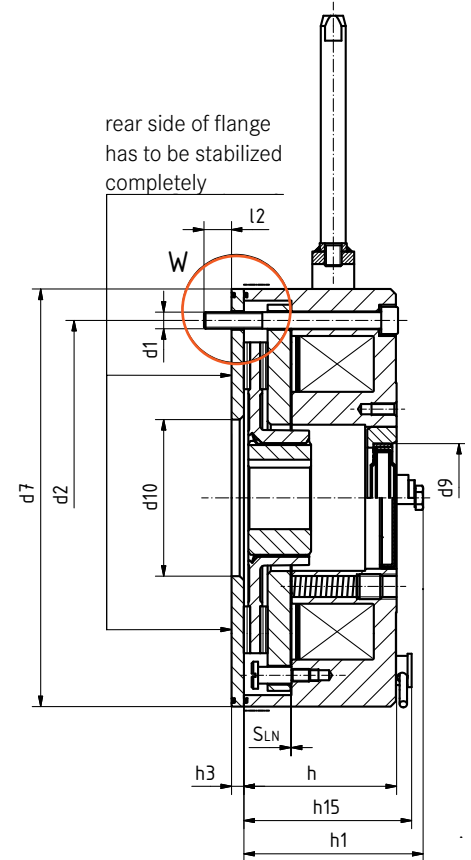

Size	M _K [Nm]	b	d ¹⁾ spec.	d ^{H7 2)} standard	d ₁	d ₂	d ₃ ^{H7}	d ₄	d ₅ ^{H7}	d ₆	d _{7(+0,2/-0,3)}	d ₉	d ₁₀	d ₁₁	d ₁₄	d ₁₅	d ₁₆ ^{H8}	d ₁₇ ^{H8}	d ₁₈ ^{H8}	d ₁₉	d _i	d _a	h	h ₁	h ₂	h ₃	h ₄	h ₅
14	60	179	14	20/25/30	3xM8	145	60	100	168	168	168	52	64	12	4xM6	75	168	70	168	175	80	124	67,1	75,3	2	6	38,8	185,5
16	80	213	15	25/30/35	3xM8	170	68	110	200	200	200	52	74	12	4xM6	85	200	75	200	208	104	149	73,1	85,8	2,25	6	42,8	231
18	150	243	20	30/35/40/45	6xM8	196	75	125	226	226	226	62	95	14	4xM8	95	226	95	226	235	129	174	83,1	96,4	2,75	6	47,8	290

¹⁾ Predrilled without keyway

²⁾ Standard keyway in accordance with DIN 6885/1 P9
in case of high torques and/or reversing duty, a special hub has to be used

Brake without flange

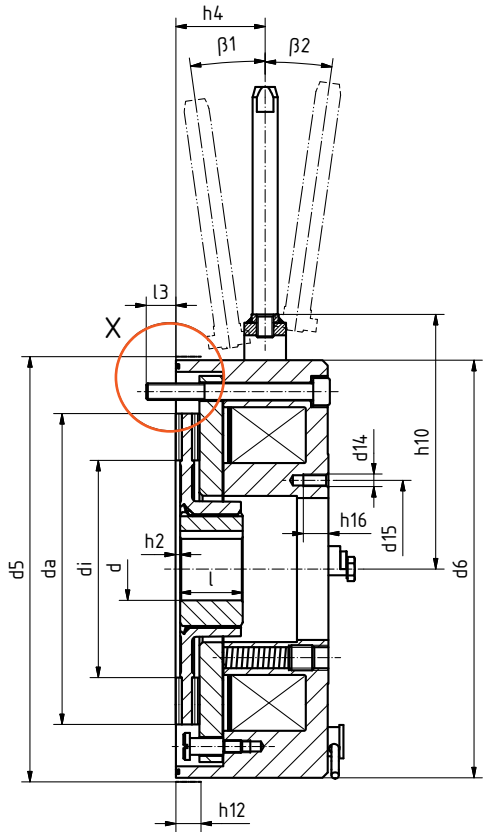

Brake with centring flange

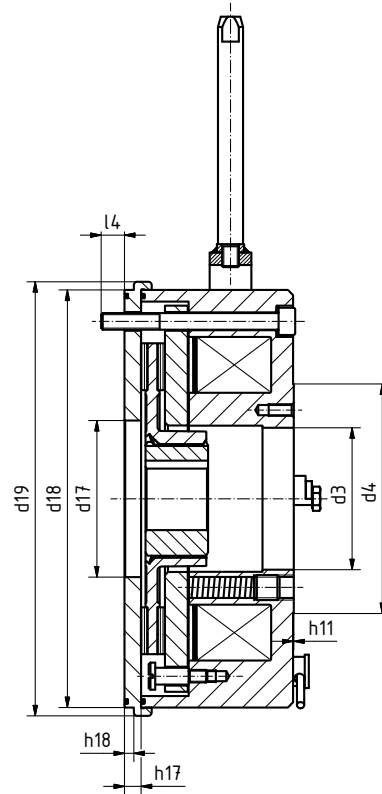

**Motor mounting plate
(position tolerance of the screw holes)**

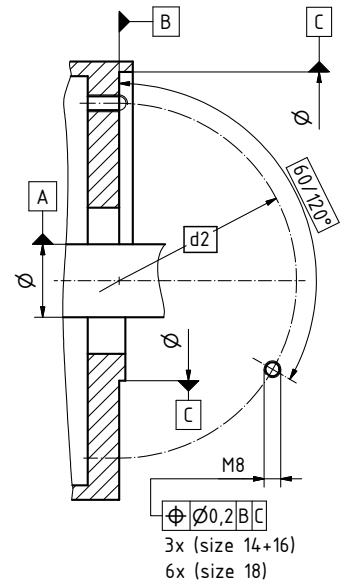

**View W
without centering**

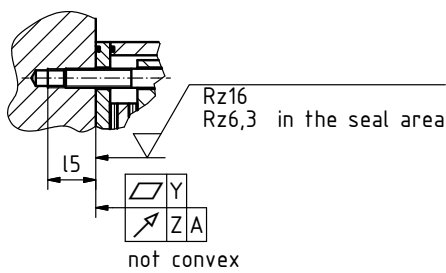

**View X
with centering**

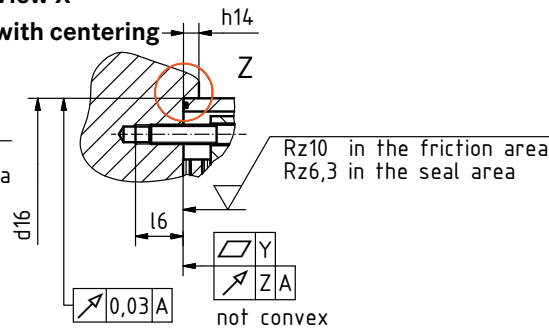

**View X
without centering**

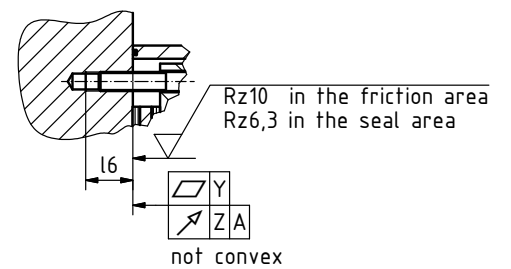

Size	h ₉	h ₁₀	h ₁₁	h ₁₂	h _{13 min.}	h _{13 max.}	h _{14 min.}	h _{14 max.}	h ₁₅	h ₁₆	h ₁₇	h ₁₈	l	l ₁	l ₂	l ₃	l ₄	l _{5 min.}	l _{6 min.}	S _{LN}	α	β _{1+3°}	β _{2+3°}	Y	Z
14	100,5	104,5	0,3	12	10	16	6,5	10	79,4	12	8	4,5	30	400	14,3	15,3	12,3	19	20	0,3 _(+0,10/-0,10)	25°	9°	8°	0,05	0,05
16	118	122	0,3	12	10	16	6,5	10	81,5	12	8	4,5	30	600	13,2/18,2 ³⁾	14,2	11,2/16,2 ³⁾	17/22 ³⁾	18	0,3 _(+0,15/-0,05)	25°	8°	8°	0,08	0,05
18	135	140	0,3	12	10	16	6,5	10	91,6	16	10	5	35	600	19,3	15,3	15,3	23	19	0,4 _(+0,20/-0,10)	25°	10°	9°	0,1	0,08

³⁾ For the CCV design
 Dimensions in mm

Functional principle

BFK470 spring-applied brake

BFK470 spring-applied brakes are single-disk brakes with two friction surfaces. When deenergised, several springs are used to generate the braking torque through friction locking. The brake is released electromagnetically. During braking, the springs use the armature plate to press the rotor (which can be shifted axially on the hub) against the counter friction face. When the brakes are applied, an air gap S_L is present between the armature plate and the stator. The stator's coil is energised with DC voltage in order to release the brake. The resulting magnetic flux works against the spring force to draw the armature plate to the stator. This releases the rotor from the spring force and allows it to rotate freely.

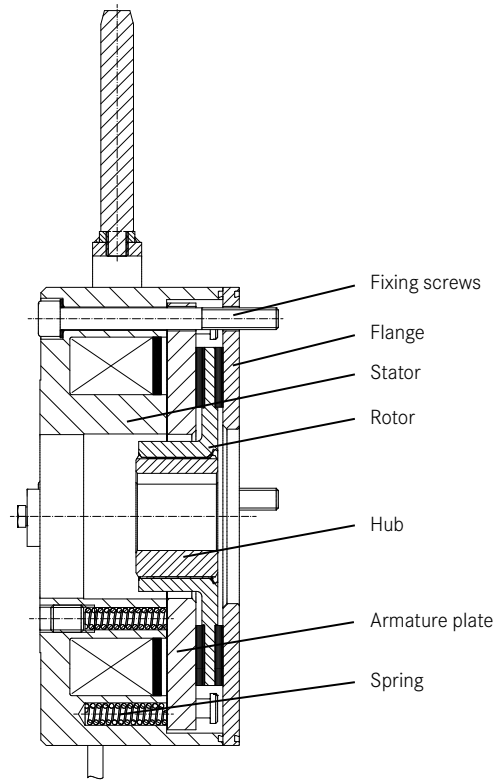

Noise-reduced aluminium rotor

The rotor with plastic sleeve reduces the rattling noises in the rotor/hub connection. At the same time, this increases the service life of this connection.

Features and advantages

- Low rate of wear between rotor and hub
- Recommended for frequency inverter operation
- Noise-reduced design
- Also available in combination with CCV

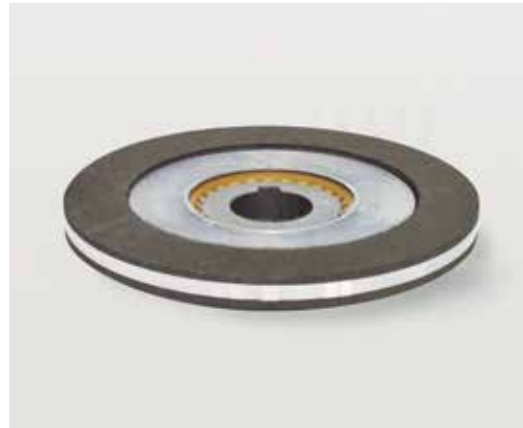

Characteristic torques

General information

INTORQ brakes are dimensioned so that the specified characteristic torques can usually be achieved reliably after a short running-in period. However, as the organic friction linings used do not all have identical properties and because environmental conditions can vary, deviations from the specified braking torques are possible. These must be taken into account in the form of appropriate dimensioning tolerances.

Increased breakaway torque is common in particular after long downtimes in humid environments where temperatures vary.

If the brake is being used on friction surfaces provided by the customer, the characteristic torque must be checked. If the brake is to be used solely as a holding brake without dynamic load, the friction lining must be reactivated at regular intervals.

Friction lining qualities

Various friction lining qualities are available for different uses and areas of application:

- **ST** Standard friction lining
- **WR** Friction lining with low rate of wear
- **HFC** High friction coefficient friction lining for high braking torques
- **RIF** Run-in-free friction lining, does not require a running-in period
- **HT** High-temperature friction lining, temperature resistant and suitable for high friction energies

The characteristic torques listed in the table apply to the standard (**ST**) and low-wear (**WR**) friction linings. The other friction linings are used primarily in holding brake and emergency stop applications. With the **HFC** and **RIF** linings, it is also possible to achieve higher characteristic torques.

Characteristic torques

Size	Characteristic torque M_k [Nm]			Reduction of characteristic torque at specified speed to x%		
	ST/WR operating brake	ST/WR/RIF/HT holding brake ²⁾	HFC/RIF holding brake ³⁾	1500 [r/min]	3000 [r/min]	max.
14	40/50/ 60 ¹⁾	40/50/ 60 ¹⁾ / 65/70/75/80/100/110	> 110	80%	73%	67%
16	55/ 80 ¹⁾	55/ 80 ¹⁾ / 90/100/105/125/150	> 150	80%	73%	67%
18	100/ 150 ¹⁾	100/ 150 ¹⁾ / 165/185/200/235/250	> 250	80%	73%	67%

■ ¹⁾ Standard characteristic torques

■ ²⁾ HT friction lining is approved for use up to 100 Nm for size 14, and up to 125 Nm for size 16 and up to 235 Nm for size 18

■ ³⁾ only for projects; consultation required with INTORQ

Characteristic torques

Features of the special friction linings

HFC (high friction coefficient)

- For higher braking torques
- Use as holding brake
- Running-in period required

RIF (run-in-free)

- Stable, static torque
- Use as holding brake
- No running-in period required
- Developed for the strict requirements placed on pitch drives in wind turbines
- Restricted maximum speed

HT (high-temperature)

- Friction lining resistant to high temperatures, allows friction energies up to a factor of 5 (in comparison with standard aluminium rotor)
- Use as holding brake
- Stable, static torque
- Particularly well suited to pitch and azimuth drives in wind turbines

As the special friction linings have been developed for specific uses and areas of application, this flyer does not contain any additional information on them. For more details, please consult the manufacturer during the project planning stage.



BFK470, aluminium rotor with toothed hub



BFK470, degree of protection IP66

Technical data

Rated data

Size	P_N [W]	s_{LN} [mm]	$s_{L \max}$ [mm] Operating brake	$s_{L \max}$ [mm] Holding brake
14	60	0.3 ±0.1	0.75	0.45
16	68	0.3 ^{+0.15} _{-0.05}	0.80	0.50
18	85	0.4 ^{+0.2} _{-0.1}	1.0	0.65

Torque time characteristic dependent on excitation voltage

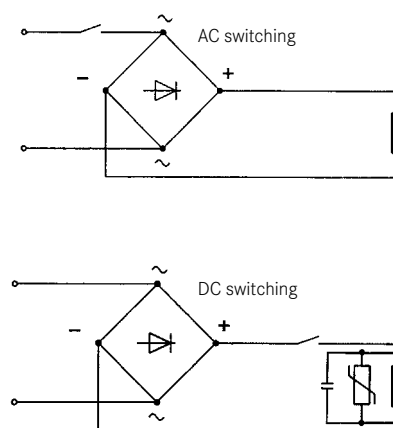
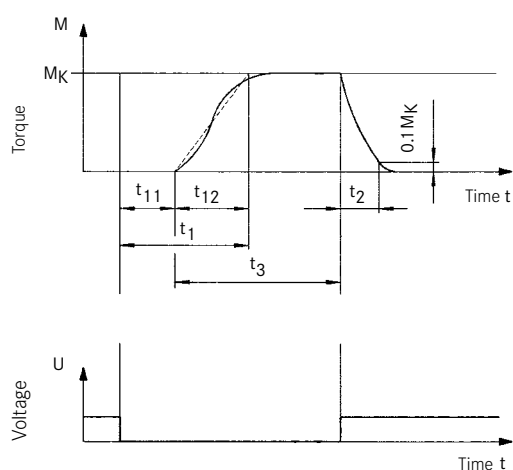

Standard aluminium rotor (ST)

The listed operating times are guide values which apply to DC switching with rated air gap s_{LN} , warm coil and standard characteristic torque.

The times specified are mean values. The engagement time t_1 is approximately 8 to 10 times longer for AC switching.

Size	Characteristic torque M_K [Nm]	Maximum speed n_{max} [r/min]	Q_E [J]	S_{hue} [1/h]	Operating times [ms]			
					Connection on the DC side			Disconnection
					t_{11}	t_{12}	$t_1 = t_{11} + t_{12}$	t_2
14	60	3600	30,000	28	30	47	77	162
16	80	3600	36,000	27	46	62	108	225
18	150	3600	60,000	20	62	92	154	343

Technical data

Aluminium rotor with low rate of wear (WR)

The wear values in the table apply to the friction lining with low rate of wear and to the standard characteristic torque. The friction energies specified up to the point of maintenance are rough guide values that are subject to a high degree of variation depending on various influencing factors.

Size		14	16	18
Q_E Maximum permissible friction work per switching cycle [J]				
	100 r/min	30,000	36,000	60,000
	1000 r/min	30,000	36,000	60,000
	1200 r/min	30,000	36,000	60,000
	1500 r/min	30,000	36,000	60,000
	1800 r/min	30,000	36,000	36,000
	3000 r/min	18,000	11,000	on request
	3600 r/min		on request	
Q _{BW}	[10 ⁶ J]	571	966	1542
S _{hue}	[h ⁻¹]	28	27	20

Q_{BW} = Friction energy of brake until maintenance
S_{hue} = Transitional operating frequency

In the region of the load limit (operation > 50% Q_E) the value for Q_{BW} can drop as low as 40%.



Conveyor technique



Wind turbines

Technical data

Service life and wear

Friction energy and operating frequency

For the standard (ST) and low-wear (WR) friction linings

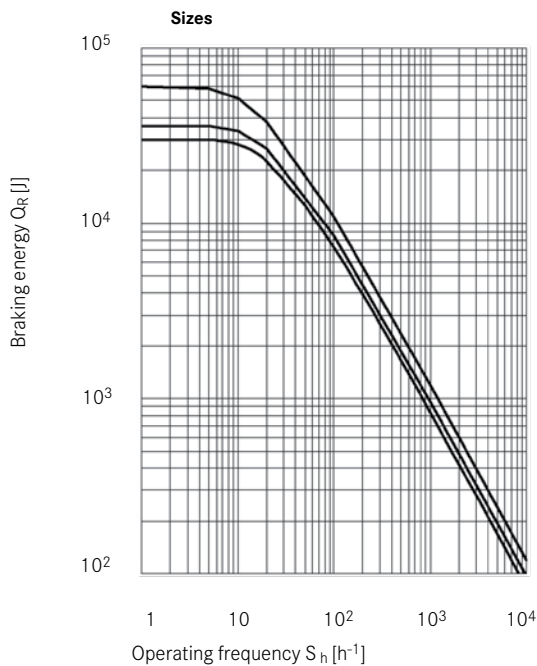

$$S_{hmax} = \frac{-S_{hue}}{\ln\left(1 - \frac{Q_R}{Q_E}\right)} \quad Q_{smax} = Q_E \left(1 - e^{-\frac{S_{hue}}{S_h}}\right)$$

The maximum permissible operating frequency S_{hmax} depends on the braking energy Q_R . The specified operating frequency S_h results in the permissible switching energy Q_{smax} . Higher speed and switching energy values increase wear, because the friction surfaces are briefly subjected to very high temperatures.

The friction energy that can be withstood up to the wear limit of the brake is dependent on a number of factors: in particular, the inertias to be braked, the braking speed, the operating frequency and the resulting temperature on the friction surfaces. In addition, increased wear should be expected with a vertical brake shaft.

Where the amount of friction energy per switching operation is low, the brake's mechanical components can impose limitations in terms of service life. In particular, the rotor/hub connection, springs, armature plate and cylindrical pins are subject to operational wear. The expected service life of the standard design is around 1 million load alternations. Solutions that are optimised in terms of service life are available in cases where a longer service life is required (consult the manufacturer).

Maintenance

Brakes are components which are subject to a great deal of wear. When installing the brake, it must be ensured that it can be easily accessed for inspection and maintenance purposes. Intervals between inspections should be set in accordance with the expected service life and load. For more information, please see the operating instructions.

Product overview

BFK470 spring-applied brake

Size	<input type="checkbox"/> 14	<input type="checkbox"/> 16	<input type="checkbox"/> 18
Degree of protection	<input type="checkbox"/> IP54	<input type="checkbox"/> IP66	
Design	<input type="checkbox"/> With flange	<input type="checkbox"/> Without flange	
Voltage	<input type="checkbox"/> 24 V	<input type="checkbox"/> 103 V	<input type="checkbox"/> 180 V <input type="checkbox"/> 205 V
Characteristic torque	<input type="checkbox"/> Size 14: 40/50/ 60 ¹⁾ /65/70/75/80/100/110* <input type="checkbox"/> Size 16: 55/ 80 ¹⁾ /90/100/105/125/150* <input type="checkbox"/> Size 18: 100/ 150 ¹⁾ /165/185/200/235/250*		
	¹⁾ Standard characteristic torque * Higher braking torques possible in combination with a special friction lining Consultation with manufacturer required		
Cable length	<input type="checkbox"/> Size 14: 400 mm <input type="checkbox"/> Size 16: 600 mm <input type="checkbox"/> Size 18: 600 mm <input type="checkbox"/> Special lengths: from 100 – 1000 mm in 100 mm graduations from 1000 – 2500 mm in 250 mm graduations		
Temperature range	<input type="checkbox"/> Standard -20 to +50 °C <input type="checkbox"/> Optional -40 to +50 °C (CCV, Cold Climate Version)		
Hand release mounted	<input type="checkbox"/> Standard		
Tacho mounting	<input type="checkbox"/> Bores on rear side (taking into account customer sealing)		
Contactless proximity switch	<input type="checkbox"/> Switching function monitoring only available as holding brake (wear monitoring not possible)		
Cap	<input type="checkbox"/> Basic version	<input type="checkbox"/> Metal version type	
Shaft sealing ring	<input type="checkbox"/> Size 14: ø 20 - 25 - 30 mm <input type="checkbox"/> Size 16: ø 25 - 30 - 35 mm <input type="checkbox"/> Size 18: ø 30 - 35 - 40 - 45 mm	<input type="checkbox"/> according to CCV <input type="checkbox"/> according to CCV <input type="checkbox"/> according to CCV	
Aluminium rotor	<input type="checkbox"/> Standard <input type="checkbox"/> Standard and noise-reduced <input type="checkbox"/> Low rate of wear <input type="checkbox"/> Low rate of wear and noise-reduced <input type="checkbox"/> Special friction lining <input type="checkbox"/> Special friction lining and noise-reduced		
Hub	<input type="checkbox"/> Size 14: ø 20 - 25 - 30 mm <input type="checkbox"/> Size 16: ø 25 - 30 - 35 mm <input type="checkbox"/> Size 18: ø 30 - 35 - 40 - 45 mm	} other bore diameters } on request	
	Standard bore diameter; in case of high torques and/or reversing duty, a special hub has to be used		
Flange	<input type="checkbox"/> Standard	<input type="checkbox"/> Sealed	
Centering flange	<input type="checkbox"/> Standard	<input type="checkbox"/> Sealed	
Fixing screw set	<input type="checkbox"/> For mounting with flange <input type="checkbox"/> For mounting with CCV flange	<input type="checkbox"/> For mounting without flange <input type="checkbox"/> For mounting without CCV flange	

Setting standards in the market, worldwide

We are available to our customers at all times and in all locations. Major customers and projects are supported directly by our Key Account Sales Team at our HQ in Aerzen (Germany) or by our locations in Shanghai (China) and Atlanta (USA).

In addition to this, we work with a global network of local trading partners and cooperate with Lenze's global sales organisation.

Please send service requests directly to your local sales partner or to our HQ in Aerzen, Germany:

E-mail service@intorq.de

Tel: +49 5154 70534-444

Fax: +49 5154 70534-200

You can find more information on our products, as well as catalogues and operating instructions available for download, on our website at www.intorq.de



